



**Revell Environmental Manufacturing Inc.**

sales@remfilters.com (888) 526-4736 Lic. No. 857410

Northern California 960-B Detroit Avenue Concord, California 94518 P: (925) 676-4736 F: (925) 676-8676	Southern California 2110 South Grand Avenue Santa Ana, California 92705 P: (714) 557-2676 F: (714) 557-2679
--	---

**INSTALLATION INSTRUCTIONS FOR THE TRITON MODEL: CPS - FTC**

**Step 1)** CPS (Crescent Pipe Screens) have been designed to be placed in front of the downstream exit pipe in a catch basin.

**Step 2)** Clean bottom of catch basin where the CPS Filter will be installed.

**Step 3)** Place CPS filter into position. Using a hammer drill with 1/4" masonry drill bit, drill through existing mounting plates pre-drilled holes that are attached to both the bottom and sides of the CPS Filter. Hammer in anchor bolt (Red Head), place washer over plate, then tighten down with nut using a 7/16" socket drive. Some units may or may not require the use of side mounting tabs.

**Step 4)** If Deflector Plate with Elevated Vector Access or a Deflector Plate is to be installed, position either of them 6" above the top of the CPS Filter. Place the Deflector plate against the wall, 6" above the CPS unit, then using the existing pre-drilled holes in the brackets, mark or drill through the holes used for the anchor bolts. Hammer in anchor bolts, place washer over plate, then tighten down with nut using a 7/16" socket drive.

The Contour Apron is flexible enough to bend to the contour of a sloped catch basin floor. Three to four anchor bolts should be adequate to secure apron to catch basin floor. (See Figure #3)

If you need further assistance please call us direct at (888) 526-4736 or email us your questions at: [Sales@remfilters.com](mailto:Sales@remfilters.com)

**TOOLS REQUIRED:**

- 1) Hammer Drill, with 1/4" masonry drill bit.
- 2) Hammer.
- 3) 1/4" X 2" or 3" Concrete Anchors. i.e. (Red Head)
- 4) 7/16" Socket Drive.

Typical view of installation area

Figure #1

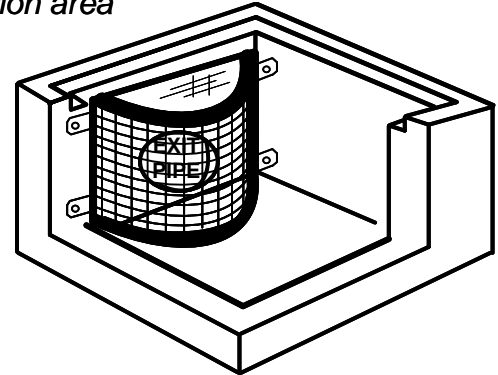

**MADE IN USA**

Typical view of installation area

Figure #2

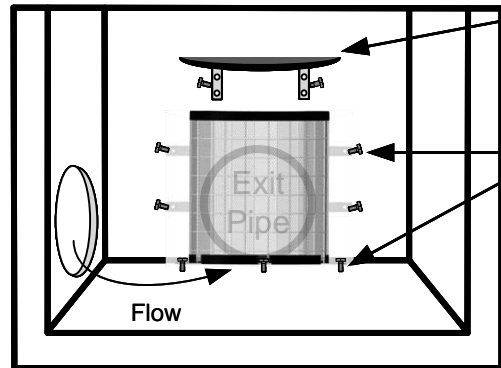

**Optional Deflector Plate**  
To be mounted when needed or required.

**Stainless Steel Mounting Anchors**  
Simply drill holes for 1/4" anchors

Figure #3

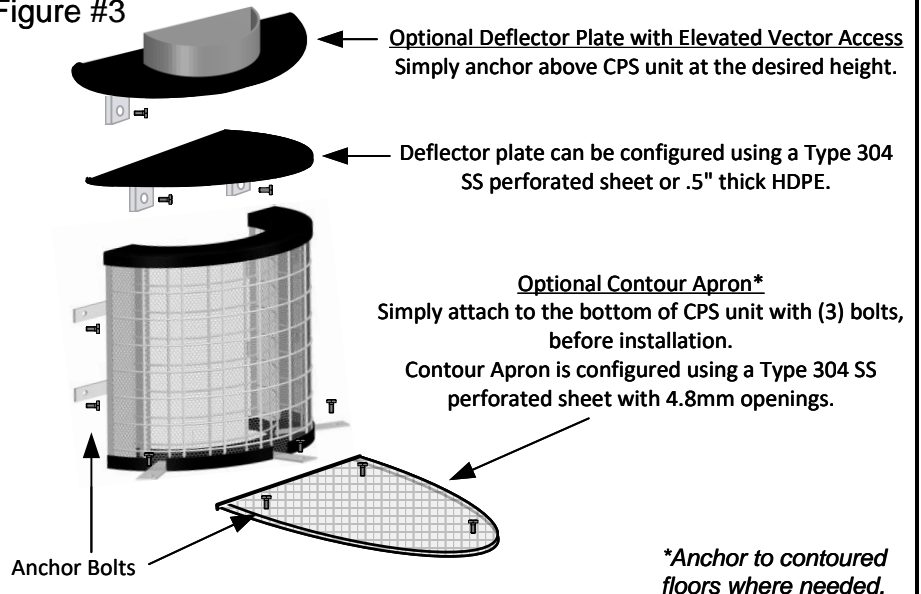

**Optional Contour Apron\***  
Simply attach to the bottom of CPS unit with (3) bolts, before installation.  
Contour Apron is configured using a Type 304 SS perforated sheet with 4.8mm openings.

\*Anchor to contoured floors where needed.

TOP VIEW

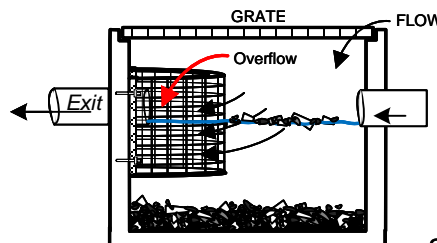
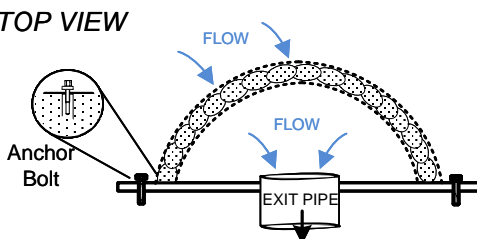

SIDE VIEW

