

Sizing Guide to determine type of grate being used.

CATCH BASIN SIZING GUIDE

(Designed to help determine what size filters are required for each catch basin on site)

For Curb Inlets please call (888) 526-4736.

Once you have sized your drains you may either fax or email back your measurements to:

Fax: (925) 676-8676
Or
Email: Sales@remfilters.com

Customer: _____ Contact: _____

Ph: (____) _____ Fax: (____) _____

Project/Tract#: _____

Location: _____ Page _____ of _____

Grate Type, Mark one.

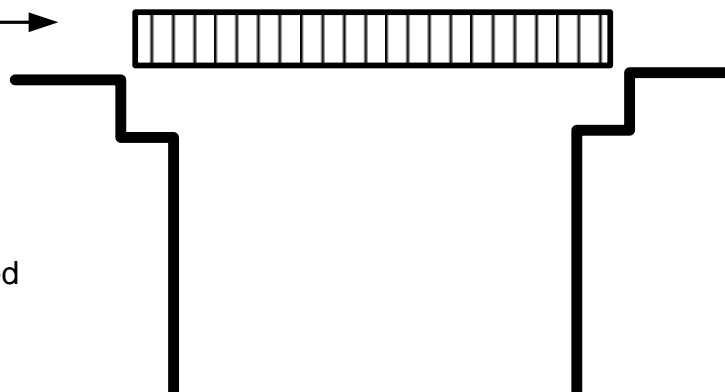
A Flat Bottom (A) → 

Note: Most commonly found on all sized catch basin grates.

C Flat top "Keyhole" / Coped Bottom (C) → 

Note: Most commonly found on 24" X 36" ID Catch Basins.

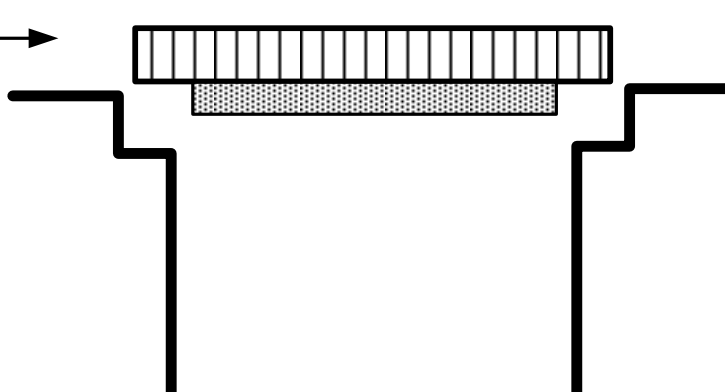
B "Keyhole" / Coped Bottom (B) → 

Note: Most commonly found on 24"X24", 24"X36", 30"X30" ID Catch Basins.

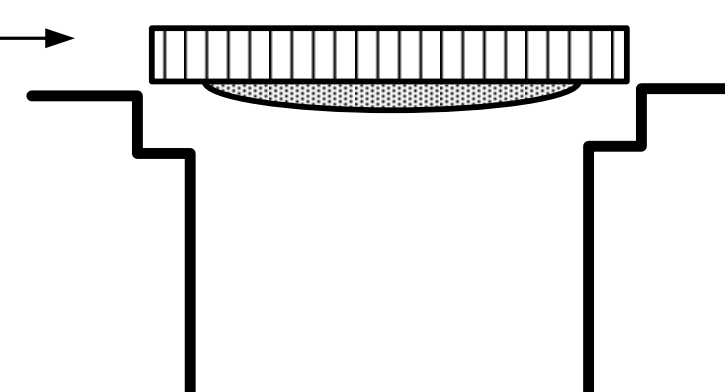
D "Keyhole" / Rounded Bottom (D) → 

Note: Most commonly found on 18" Dia., 24"Dia. and 36"Dia. Round Catch Basins.

COMMENTS:

Sizing Guide for Catch Basins having Manhole Structures

REM Inc.

MANHOLE SIZING GUIDE

(Designed to help determine what size filters are required for each catch basin on site)

For Curb Inlets or other questions please call (888) 526-4736.

Once you have sized your drains you may either fax or email back your measurements to:

Fax: (925) 676-8676
Or
Email: Sales@remfilters.com

Customer: _____ Contact: _____

Ph: (____) _____ Fax: (____) _____

Project/Tract#: _____

Location: _____ Page _____ of _____

Drain #	Quantity	Manhole / Catch Basin I.D.				Grate Dimensions			
		A	B	C	D	E	F	G	H

G, H & F – Dimensions:

Grate Type, Mark one.

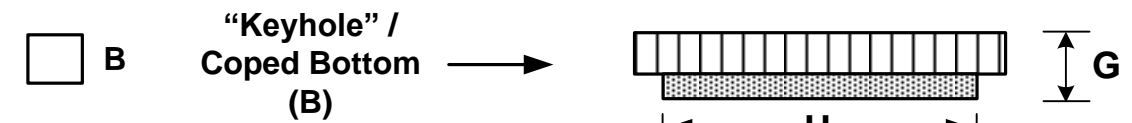

(E/F: If grate is square)

NOTES:

1. Please fill in all dimensions that apply within 1/8".
2. Please mark or draw in the location of any obstructions such as pipes, ladder rungs, etc.
3. Dimension A is the clear openings or (inside throat) of the catch basin or grate frame, whichever is less.
4. Dimension C is measured from the bottom of the neck or slab to the bottom of the catch basin.
5. Dimension D is measured from the bottom of the grate to the top of the outlet pipe.

COMMENTS:

Manhole with a coned top

The thickness of the concrete throat before it expands below

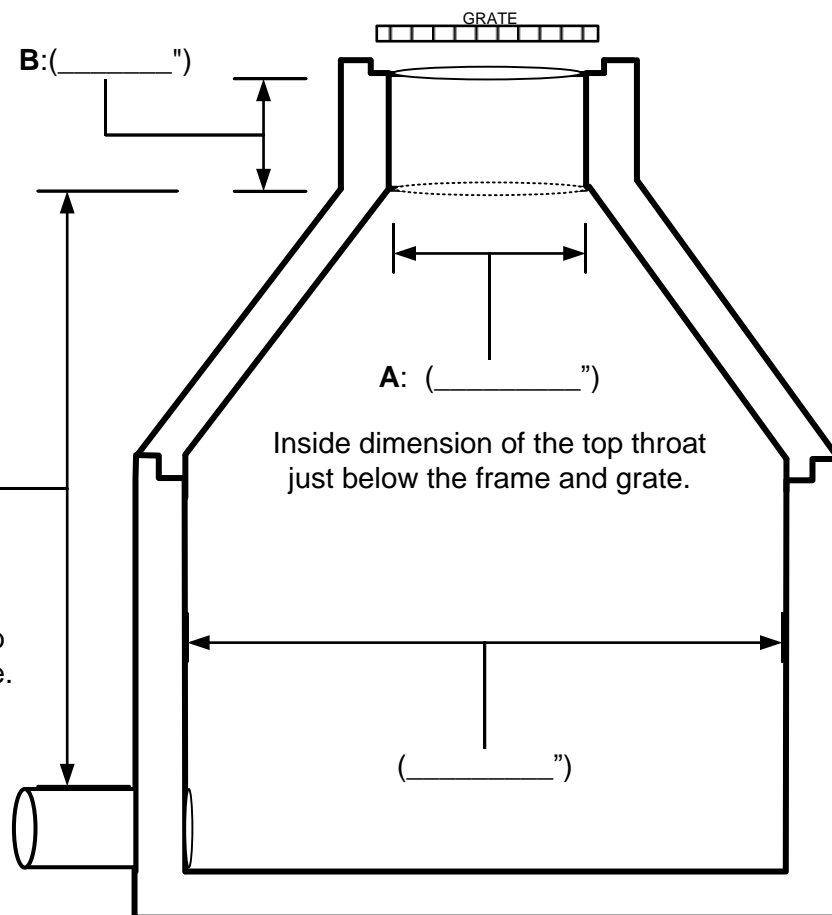

The depth of the catch basin

C: (____) "

A: (____) "

Inside dimension of the top throat just below the frame and grate.

D: (____) "

Inside depth from the inside top slab to highest exit pipe.

Manhole with a flat top cap

The thickness of the top slab

B: (____) "

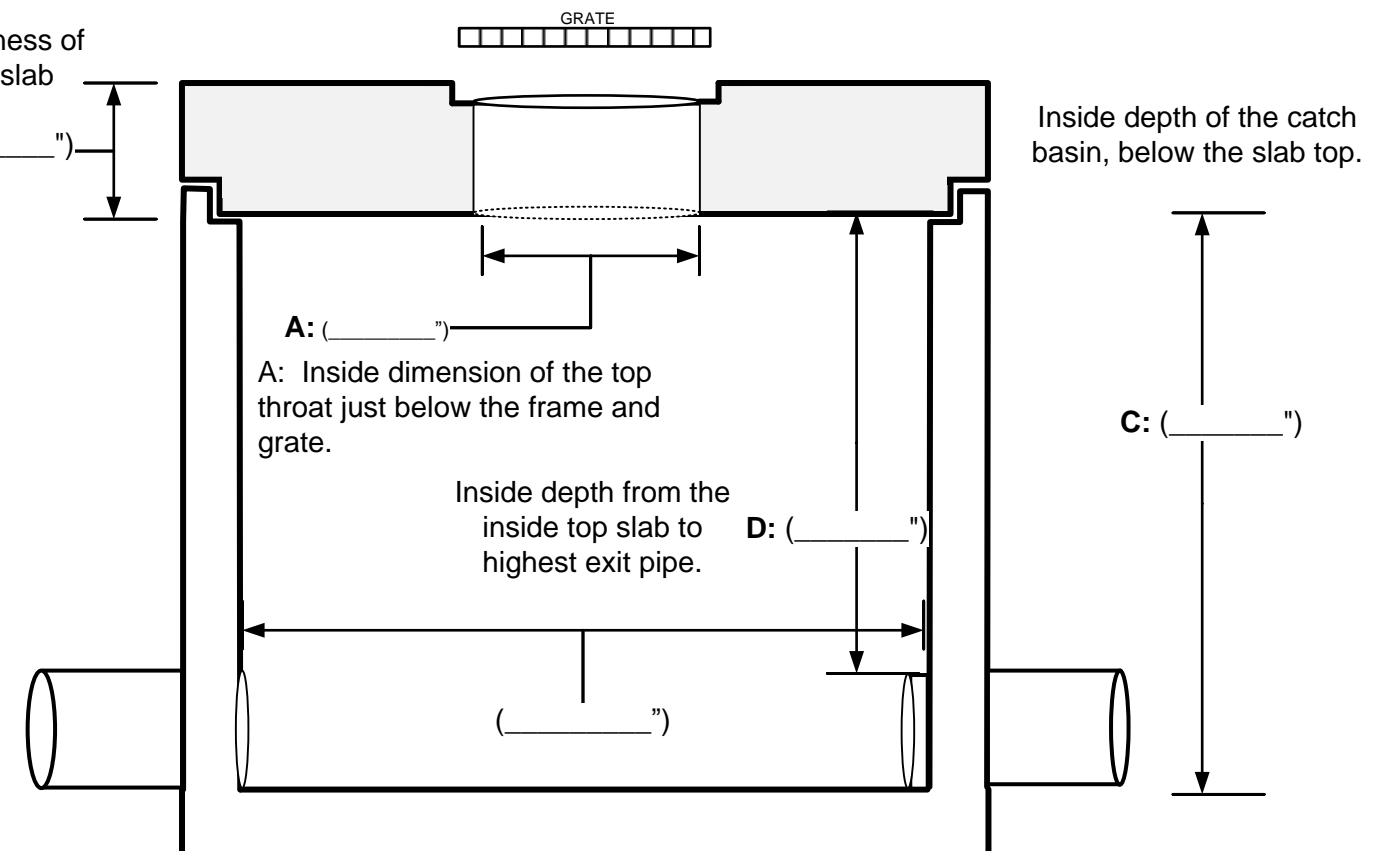

Inside depth of the catch basin, below the slab top.

C: (____) "

A: (____) "

A: Inside dimension of the top throat just below the frame and grate.

Inside depth from the inside top slab to highest exit pipe.

D: (____) "

**Sizing Guide for Square Drop Inlet Catch Basins
With Oil Stop outlets**

REM Inc.

CATCH BASIN SIZING GUIDE

(Designed to help determine what size filters are required for each catch basin on site)

For Curb Inlets or other questions please call (888) 526-4736.

Once you have sized your drains you may either fax or email back your measurements to:

Fax: (925) 676-8676
Or
Email: Sales@remfilters.com

Customer: _____ Contact: _____

Ph: (____) _____ Fax: (____) _____

Project/Tract#: _____

Location: _____ Page _____ of _____

Drain #	Quantity	Catch Basin I.D.				Grate Dimensions				Oil Stop		
		A	B	C	D	E	F	G	H	I	J	K

Grate Dimensions

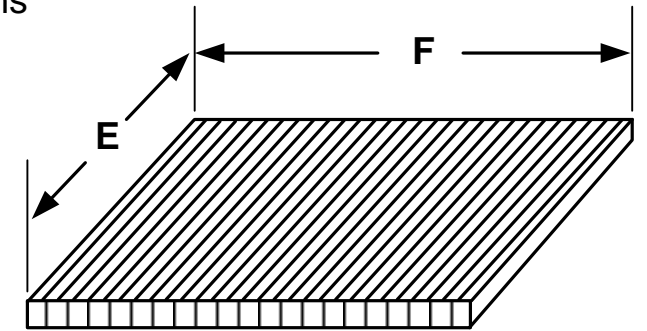

NOTES:

1. Please fill in all dimensions that apply within 1/8".
2. Please mark or draw in the location of any obstructions such as pipes, ladder rungs, etc.
3. Dimensions A & B are the clear openings or (inside throat) of the catch basin or the grate frame, whichever is less.
4. Dimension C is measured from the bottom of the grate to the bottom of the catch basin.
5. Dimension D is measured from the bottom of the grate to the top of the outlet pipe.

COMMENTS:

G & H – Dimensions:

Grate Type, Mark one.

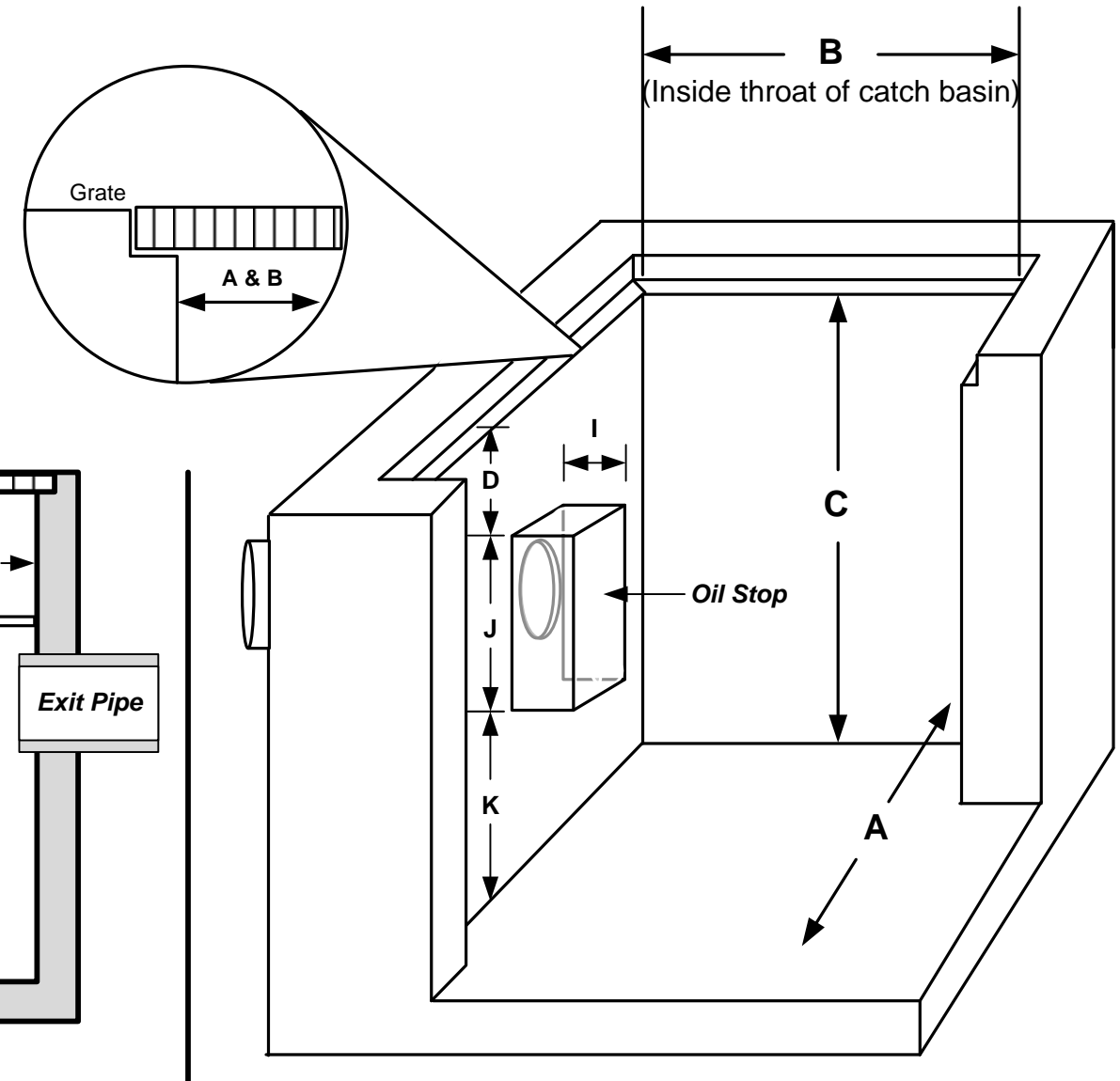
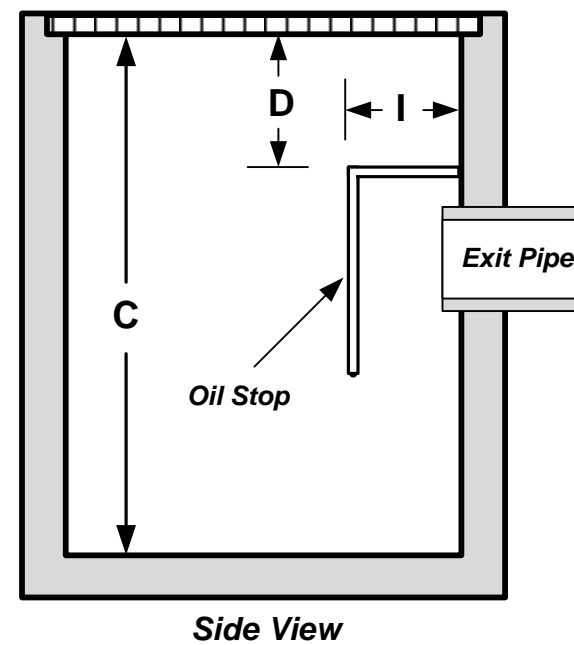
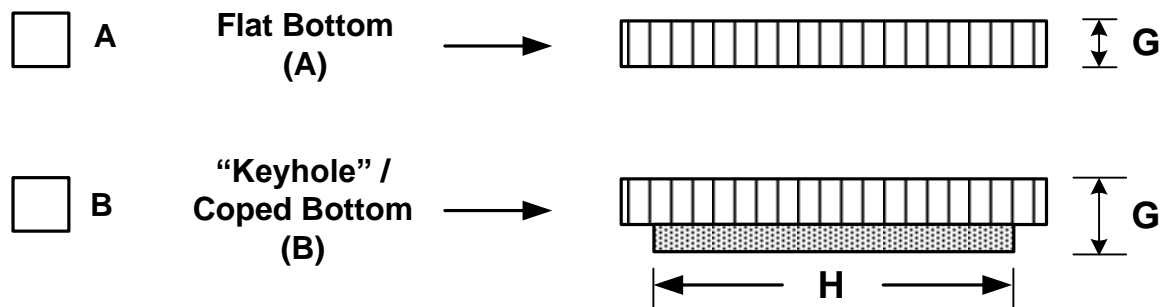

Sizing Guide for Square Drop Inlet Catch Basins

REM Inc.

CATCH BASIN SIZING GUIDE

(Designed to help determine what size filters are required for each catch basin on site)

For Curb Inlets or other questions please call (888) 526-4736.

Once you have sized your drains you may either fax or email back your measurements to:

Fax: (925) 676-8676
Or
Email: Sales@remfilters.com

Customer: _____ Contact: _____

Ph: (____) _____ Fax: (____) _____

Project/Tract#: _____

Location: _____ Page _____ of _____

Drain #	Quantity	Catch Basin I.D.				Grate Dimensions			
		A	B	C	D	E	F	G	H

NOTES:

1. Please fill in all dimensions that apply within 1/8".
2. Please mark or draw in the location of any obstructions such as pipes, ladder rungs, etc.
3. Dimensions A & B are the clear openings or (inside throat) of the catch basin or the grate frame, whichever is less.
4. Dimension C is measured from the bottom of the grate to the bottom of the catch basin.
5. Dimension D is measured from the bottom of the grate to the top of the outlet pipe.

COMMENTS:

G & H – Dimensions:

Grate Type, Mark one.

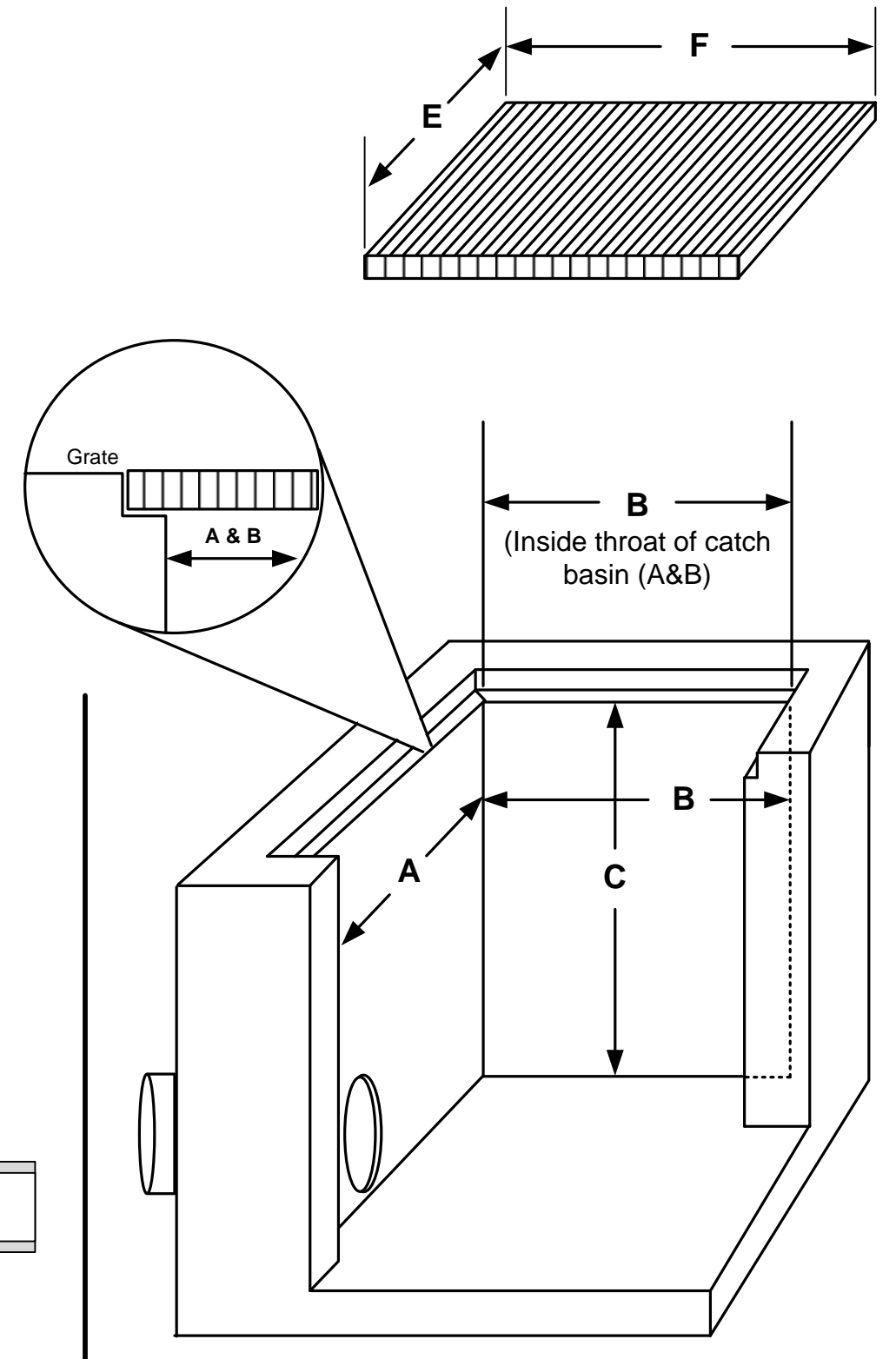
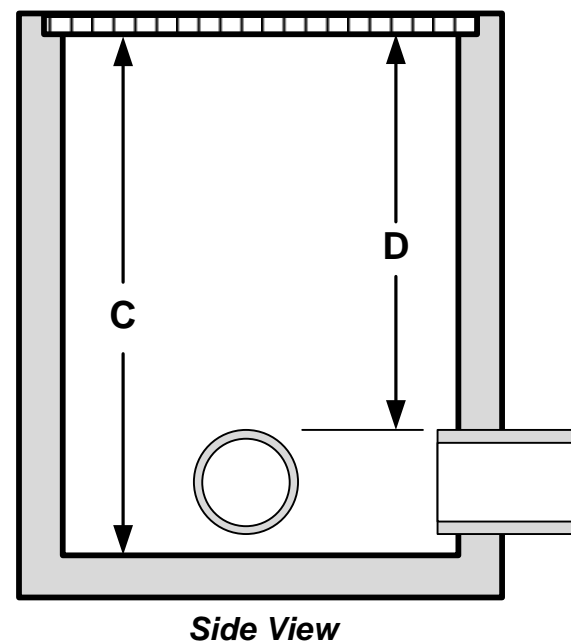
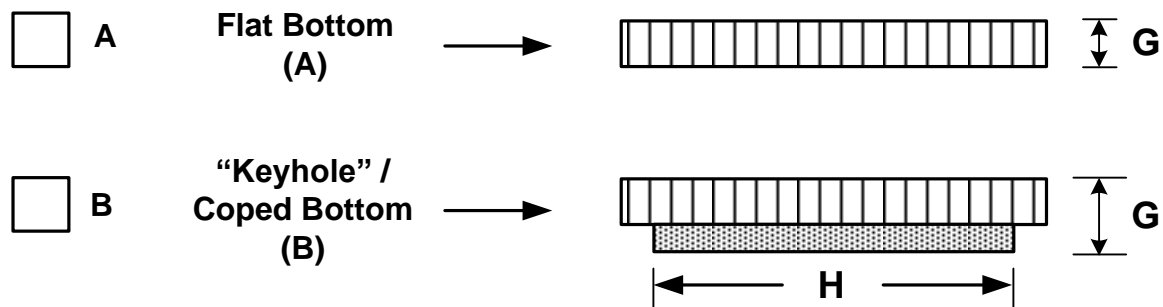

Sizing Guide for Round Drop Inlet Catch Basins

REM Inc.

CATCH BASIN SIZING GUIDE

(Designed to help determine what size filters are required for each catch basin on site)

For Curb Inlets or other questions please call (888) 526-4736.

Once you have sized your drains you may either fax or email back your measurements to:

Fax: (925) 676-8676
Or
Email: Sales@remfilters.com

Customer: _____ Contact: _____

Ph: (____) _____ Fax: (____) _____

Project/Tract#: _____

Location: _____ Page _____ of _____

Drain #	Quantity	Catch Basin I.D.				Grate Dimensions			
		A	B	C	D	E	F	G	H
			N/A				N/A		
			N/A				N/A		
			N/A				N/A		
			N/A				N/A		
			N/A				N/A		
			N/A				N/A		

NOTES:

1. Please fill in all dimensions that apply within 1/8".
2. Please mark or draw in the location of any obstructions such as pipes, ladder rungs, etc.
3. Dimensions A is the clear openings or (inside throat) of the catch basin or grate frame, whichever is less.
4. Dimension C is measured from the bottom of the grate to the bottom of the catch basin.
5. Dimension D is measured from the bottom of the grate to the top of the outlet pipe.

COMMENTS:

G & H – Dimensions:

Grate Type, Mark one.

A Flat Bottom (A) → 

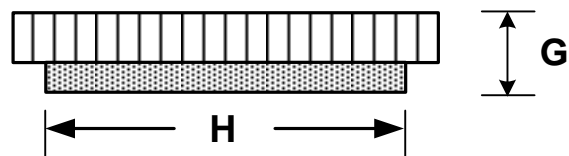
B "Keyhole" / Coped Bottom (B) → 

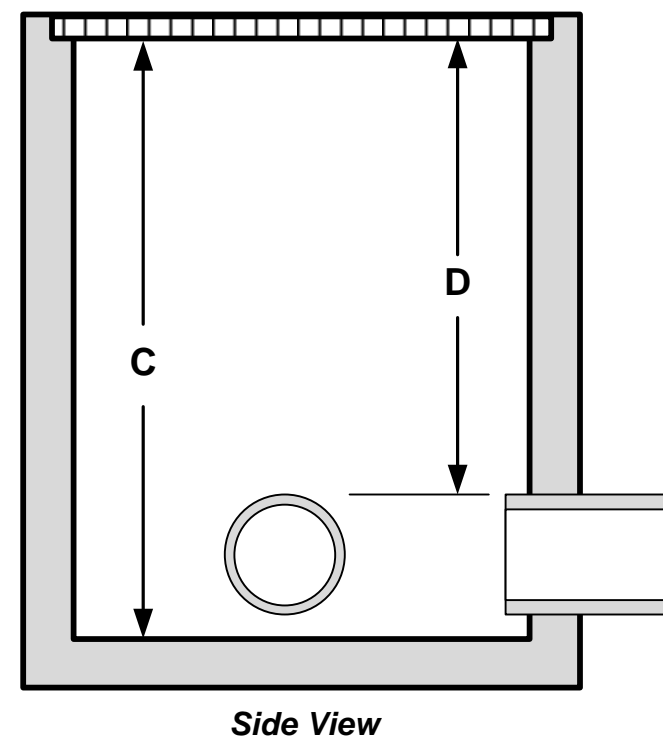
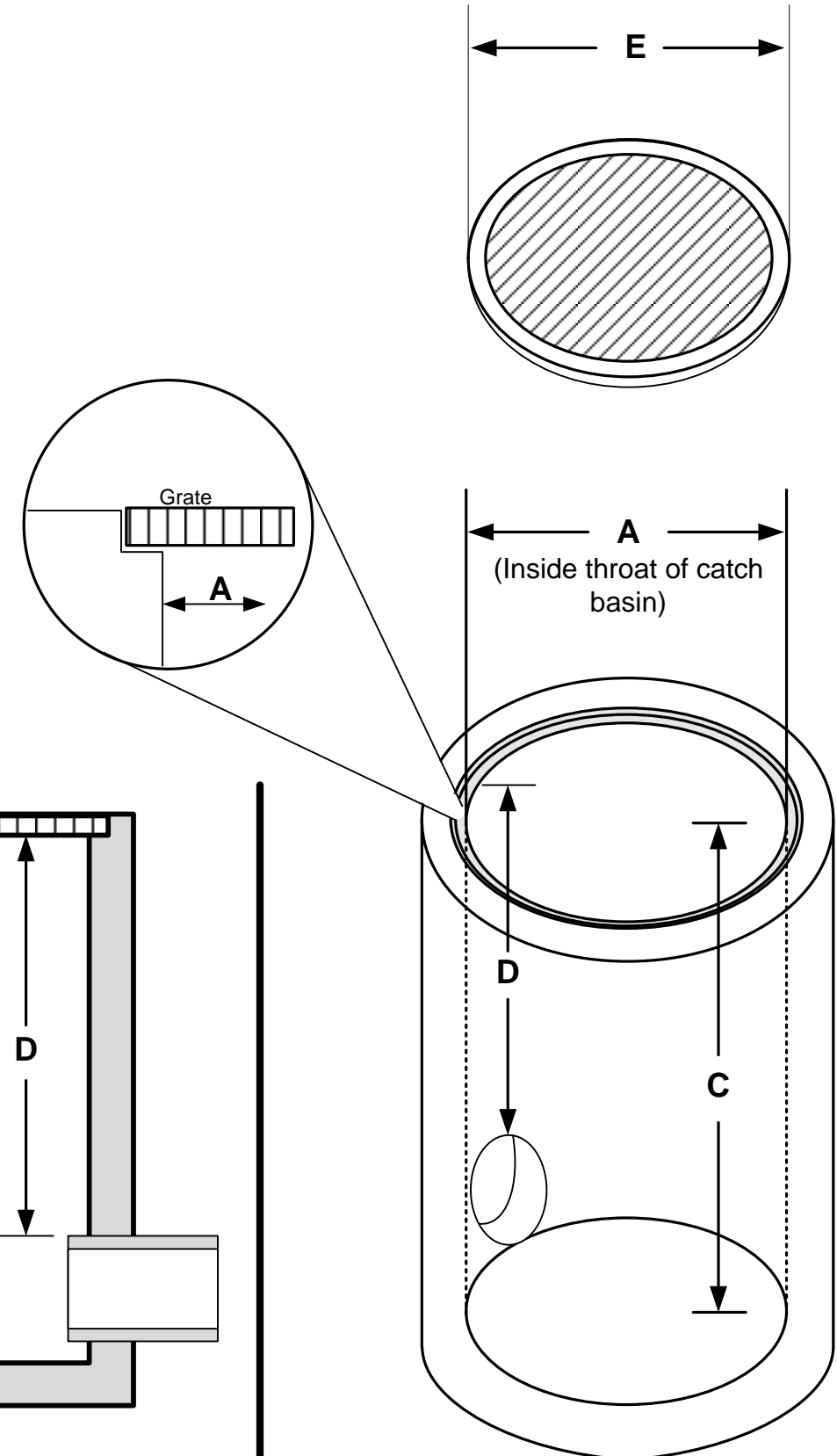

Side View

Combination Grated Curb Inlet Catch Basin Sizing Guide

REM Inc.

CATCH BASIN SIZING GUIDE

(Designed to help determine what size filters are required for each catch basin on site)

For Curb Inlets or other questions please call (888) 526-4736.

Once you have sized your drains you may either fax or email back your measurements to:

Fax: (925) 676-8676
Or
Email: Sales@remfilters.com

Customer: _____ Contact: _____
 Ph: (____) _____ Fax: (____) _____
 Project/Tract#: _____
 Location: _____ Page _____ of _____

Drain #	Quantity	Catch Basin I.D.				Grate Dimensions			
		A	B	C	D	E	F	G	H

NOTES:

1. Please fill in all dimensions that apply within 1/8".
2. Please mark or draw in the location of any obstructions such as pipes, ladder rungs, etc.
3. Dimensions A & B are the clear openings or (inside throat) of the catch basin.
4. Dimension C is measured from the bottom of the grate to the bottom of the catch basin.
5. Dimension D is measured from the bottom of the grate to the top of the outlet pipe.

COMMENTS:

G & H – Dimensions:

Grate Type, Mark one.

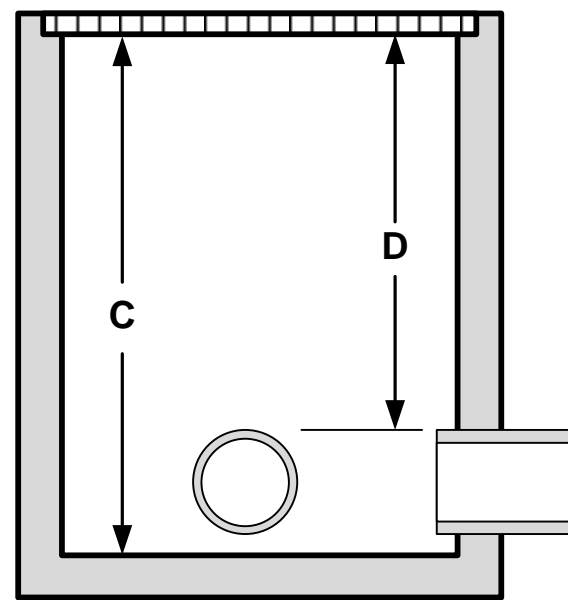
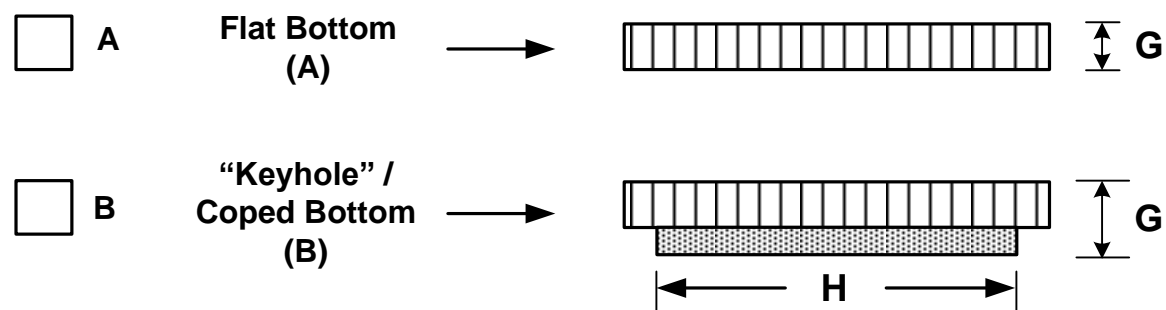

Side View

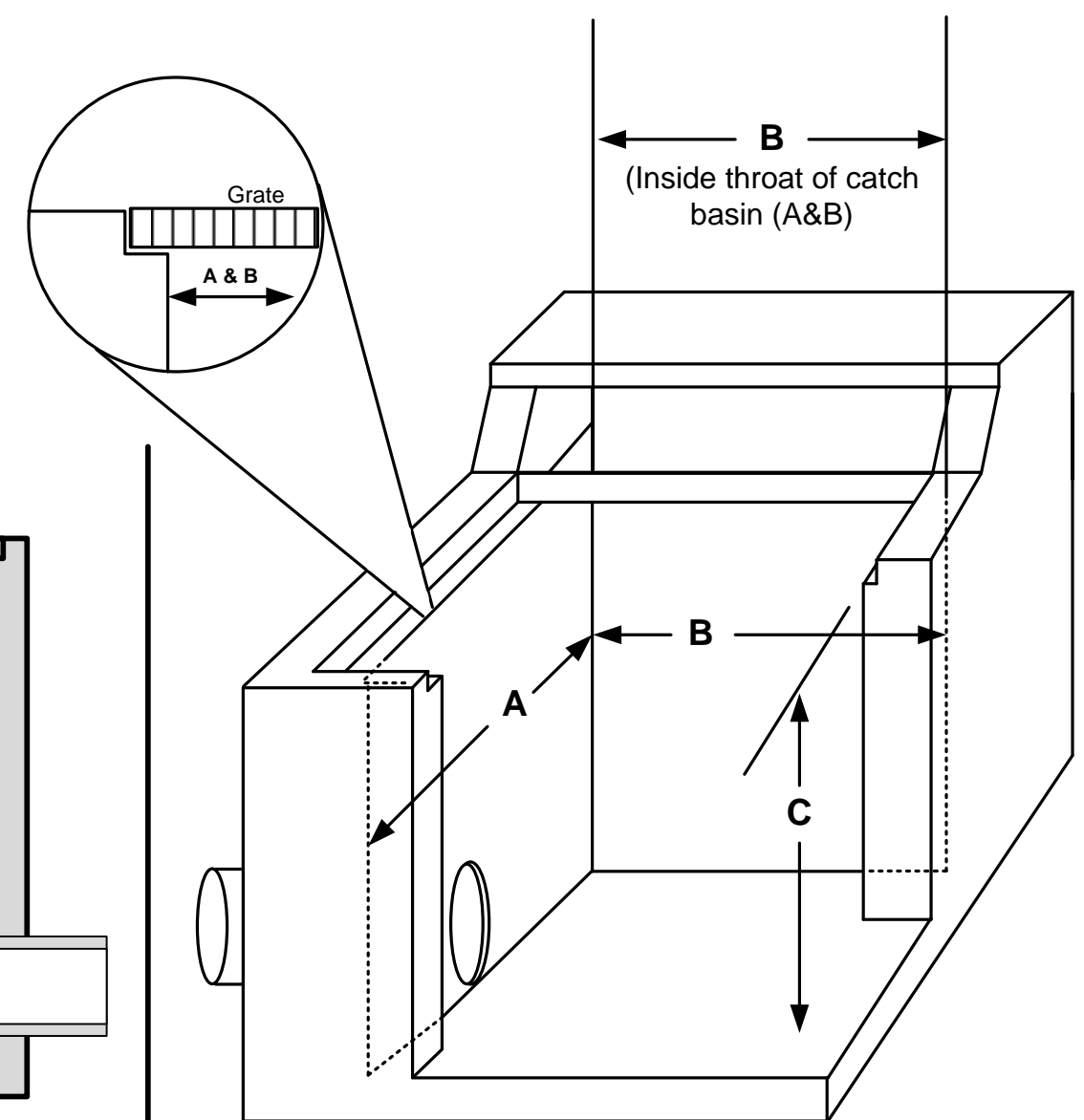
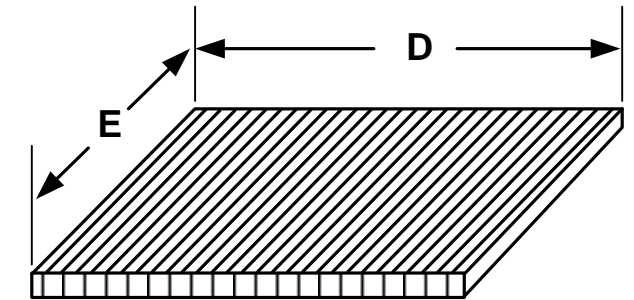

**Sizing Guide for Square Drop Inlet Catch Basins
With Oil Stop outlets**

REM Inc.

CATCH BASIN SIZING GUIDE

(Designed to help determine what size filters are required for each catch basin on site)

For Curb Inlets or other questions please call (888) 526-4736.

Once you have sized your drains you may either fax or email back your measurements to:

Fax: (925) 676-8676
Or
Email: Sales@remfilters.com

Customer: _____ Contact: _____

Ph: (____) _____ Fax: (____) _____

Project/Tract#: _____

Location: _____ Page _____ of _____

Drain #	Quantity	Catch Basin I.D.					Grate Dimensions			
		A	B1	B2	C	D	E	F	G	H

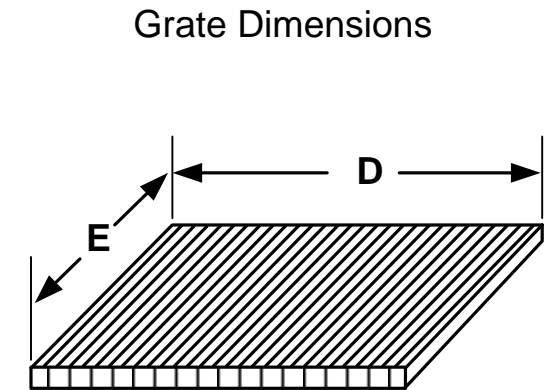
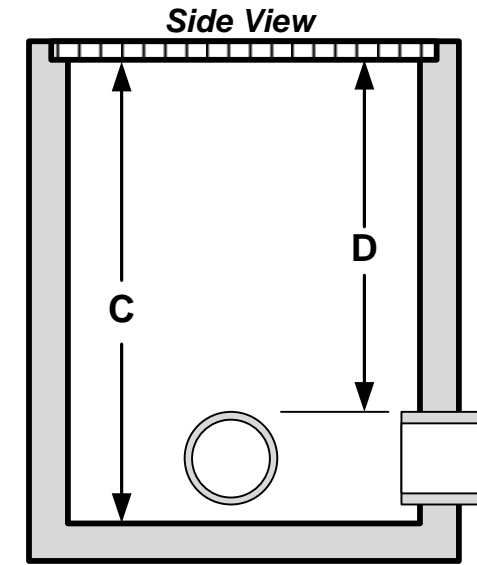

NOTES:

1. Please fill in all dimensions that apply within 1/8".
2. Please mark or draw in the location of any obstructions such as pipes, ladder rungs, etc.
3. Dimensions A & B are the clear openings or (inside throat) of the catch basin.
4. Dimension C is measured from the bottom of the grate to the bottom of the catch basin.
5. Dimension D is measured from the bottom of the grate to the top of the outlet pipe.

COMMENTS:

G & H – Dimensions:

Grate Type, Mark one.

